



# Marbach am Neckar „Neugestaltung Marktstraße“ Vorentwurf November 2020



## Anregungen der Bürgerschaft (Imakomm, Februar, September 2020)

<b>A. Städtebaulicher Rahmen</b>	<ul style="list-style-type: none"> <li>– Sanierung der Fassaden verstärkt fördern (Fördermittel weiter kommunizieren)</li> <li>– Barrierefreiheit notwendig</li> </ul>
<b>B. Erreichbarkeit</b>	<ul style="list-style-type: none"> <li>– Fahrradstellplätze für Altstadt bei Sanierung berücksichtigen</li> </ul>
<b>C. Besuchsgründe nach Zielgruppen</b>	<ul style="list-style-type: none"> <li>– Wochenmarkt am Mittwoch vergrößern / auch abends, nachmittags (Beispiel: Radolfzell)</li> <li>– Begegnungsstätte schaffen (insb. auch für Jugendliche)</li> </ul>

### SANIERUNG FUSSGÄNGERZONE – Anregungen der Bürgerbeteiligung (18.02. bis 09.0

RUBRIK	KRITIK	ANREGUNG	BETEILIGUNG
GESTALTUNG	Bedenken bezüglich Funktionsfähigkeit der Märkte	<p>Marktkonzept</p> <p>Markt komprimieren und zentralisieren, evtl. auf nachmittags / abends verlegen und bspw. um einen Tauschmarkt ergänzen</p>	<p>Informationsabend</p> <p>VerfasserIn 18, 10</p>
		<p>Optische Aufwe Gestaltung des B noch enger und</p> <p>Straßenbelag kleinteilige un</p>	



stadtmarketing  
schillerstadt marbach e.v.

VISIONEN ZUM TOURISMUS...

# Vorentwurf

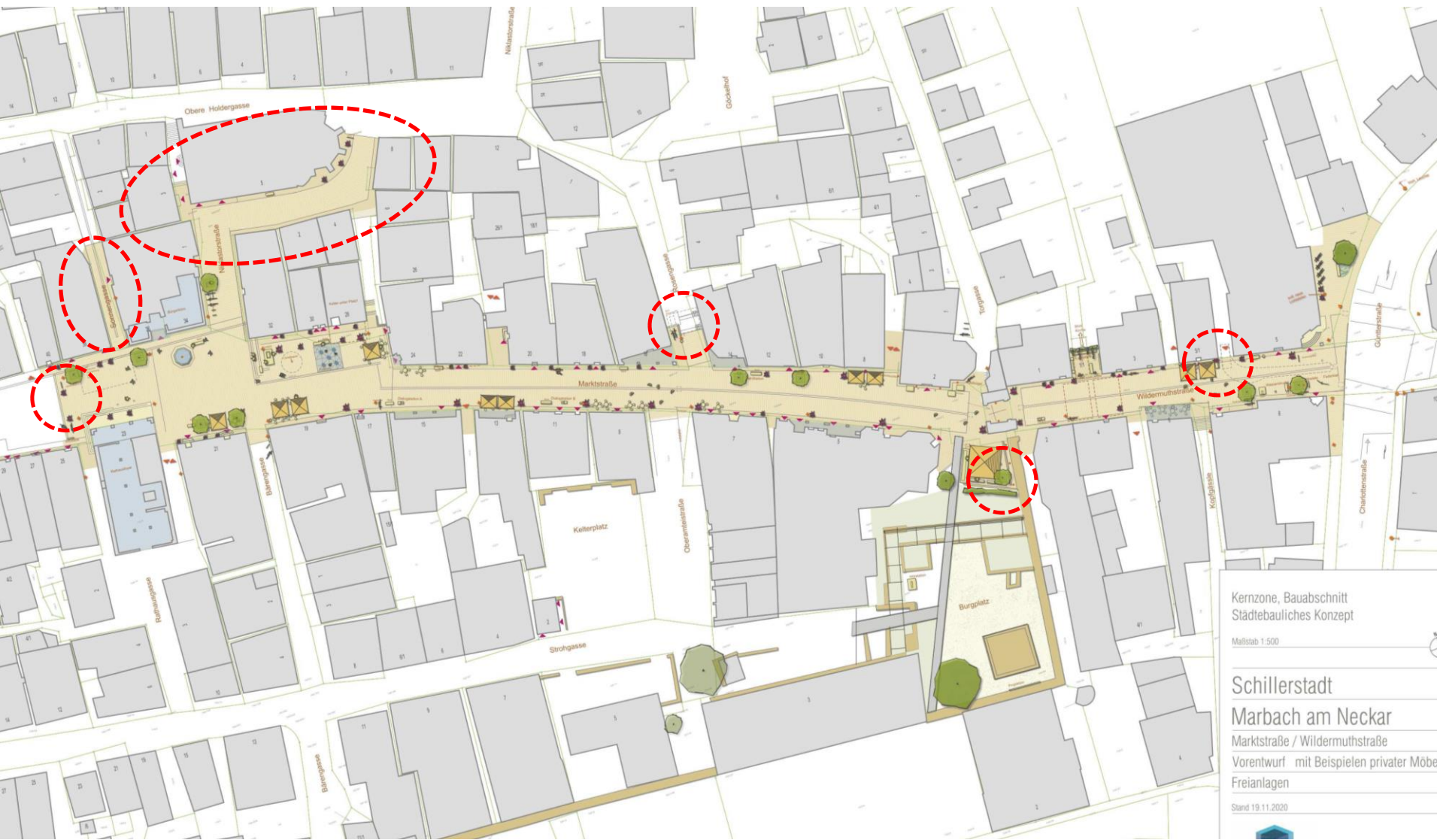

Kernzone, Bauabschnitt  
 Städtebauliches Konzept

Maßstab 1:500

Schillerstadt  
 Marbach am Neckar  
 Marktstraße / Wilderdmuthstraße  
 Vorentwurf mit Beispielen privater Möbe  
 Freianlagen

Stand 19.11.2020



# Granitbelag

Natursteinbelag, in Mörtel verlegt, Vogeser Granit, rötlich



Mitte Platten, Randbereich kleinformatiger



# Granitbelag

Natursteinbelag, in Mörtel verlegt, Vogeser Granit, rötlich



Mitte Platten, Randbereich kleinformatiger



Marbach am Neckar  
Neugestaltung Marktstraße

5

368-001  
19.11..2020



baldauf  
ARCHITEKTEN  
STADTPLÄNER



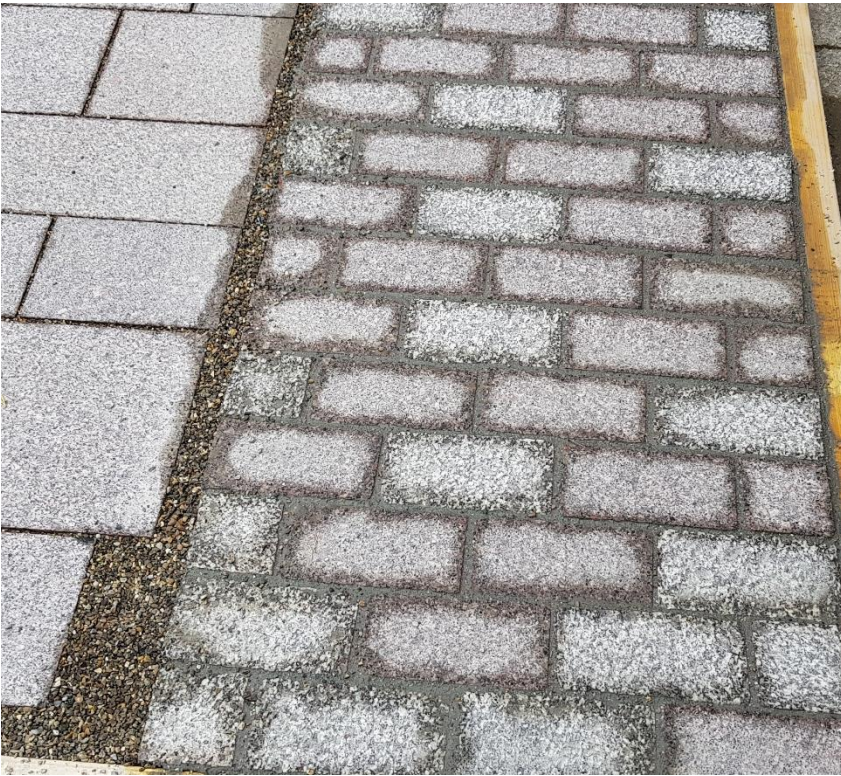

Mitte Platten, Randbereich kleinformatiger

Rinne als Basis der Leitlinien: als Mulde bzw. gefräst



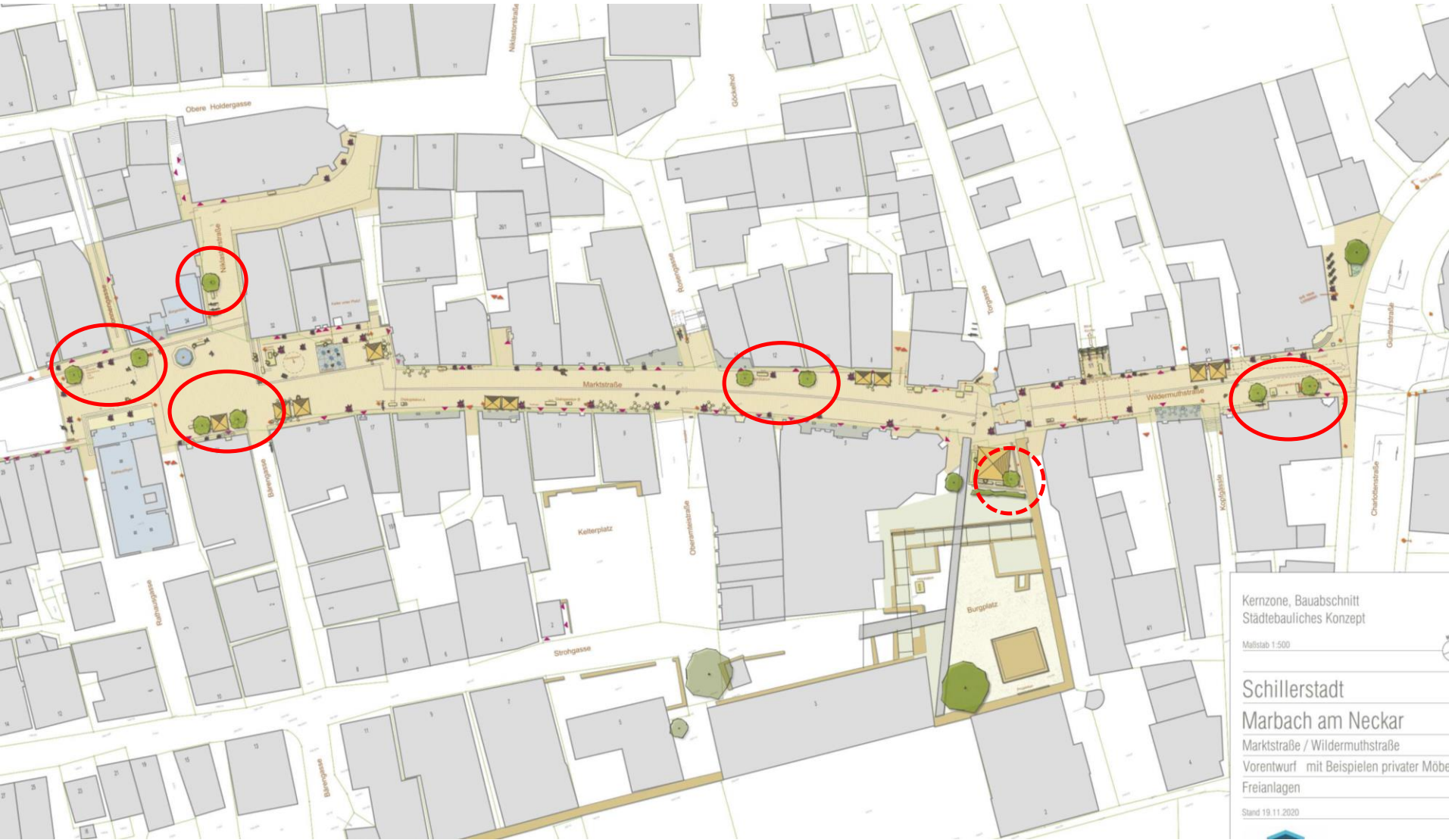

Kernzone, Bauabschnitt  
Städtebauliches Konzept

Mallstab 1:500

Schillerstadt  
Marbach am Neckar

Marktstraße / Widernuthstraße  
Vorentwurf mit Beispielen privater Möbe  
Freianlagen

Stand 19.11.2020











Beispiel Eppingen Foto: STEG Stadtentwicklung GmbH, HN

# PFLANZGEFÄSSE

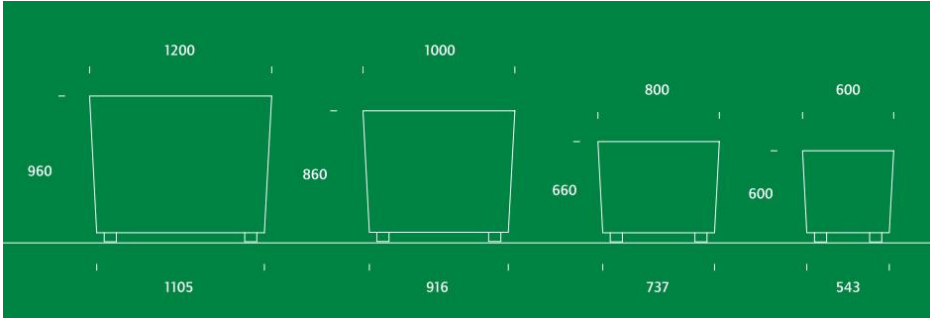



# SITZPODEST

Natursteinquader (wie Belag) mit Bankauflagen

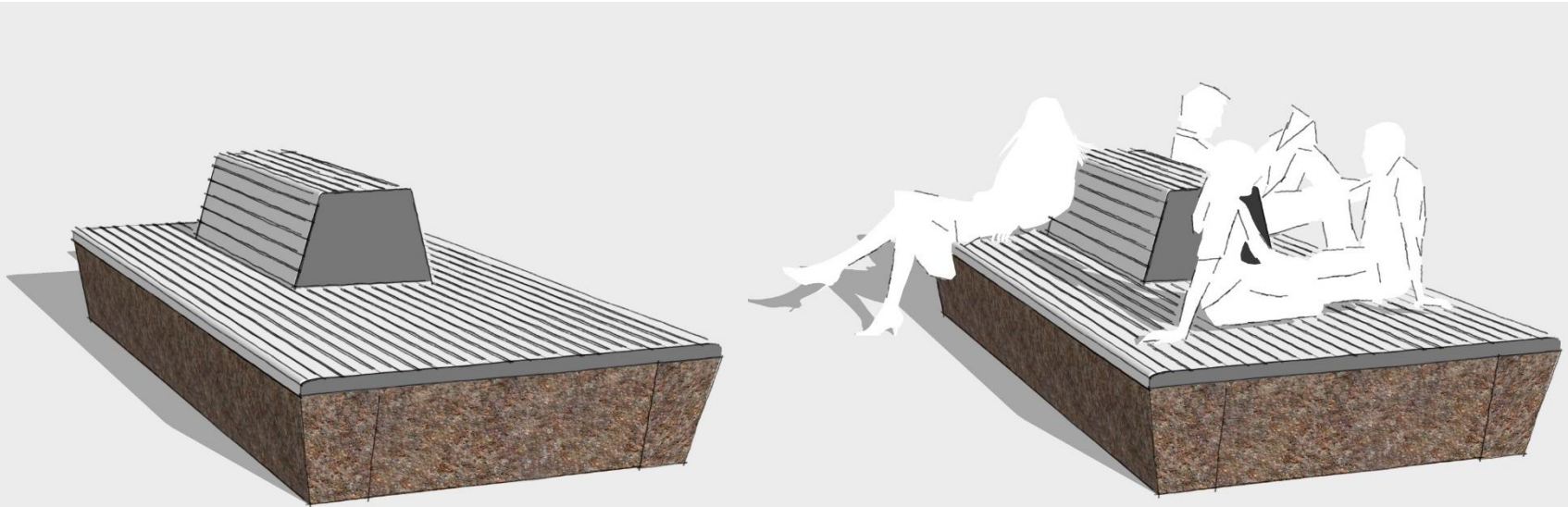

# SITZGELEGENHEITEN

## Sitzbänke

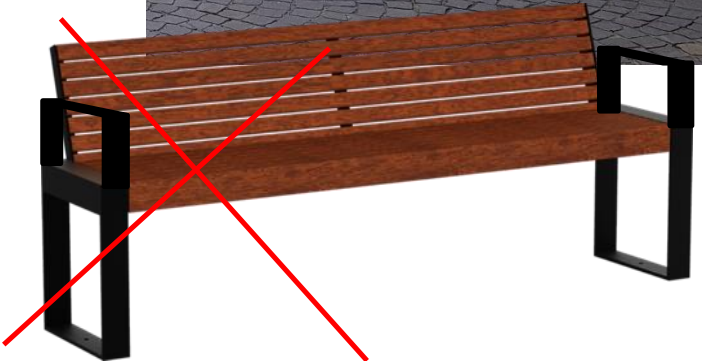



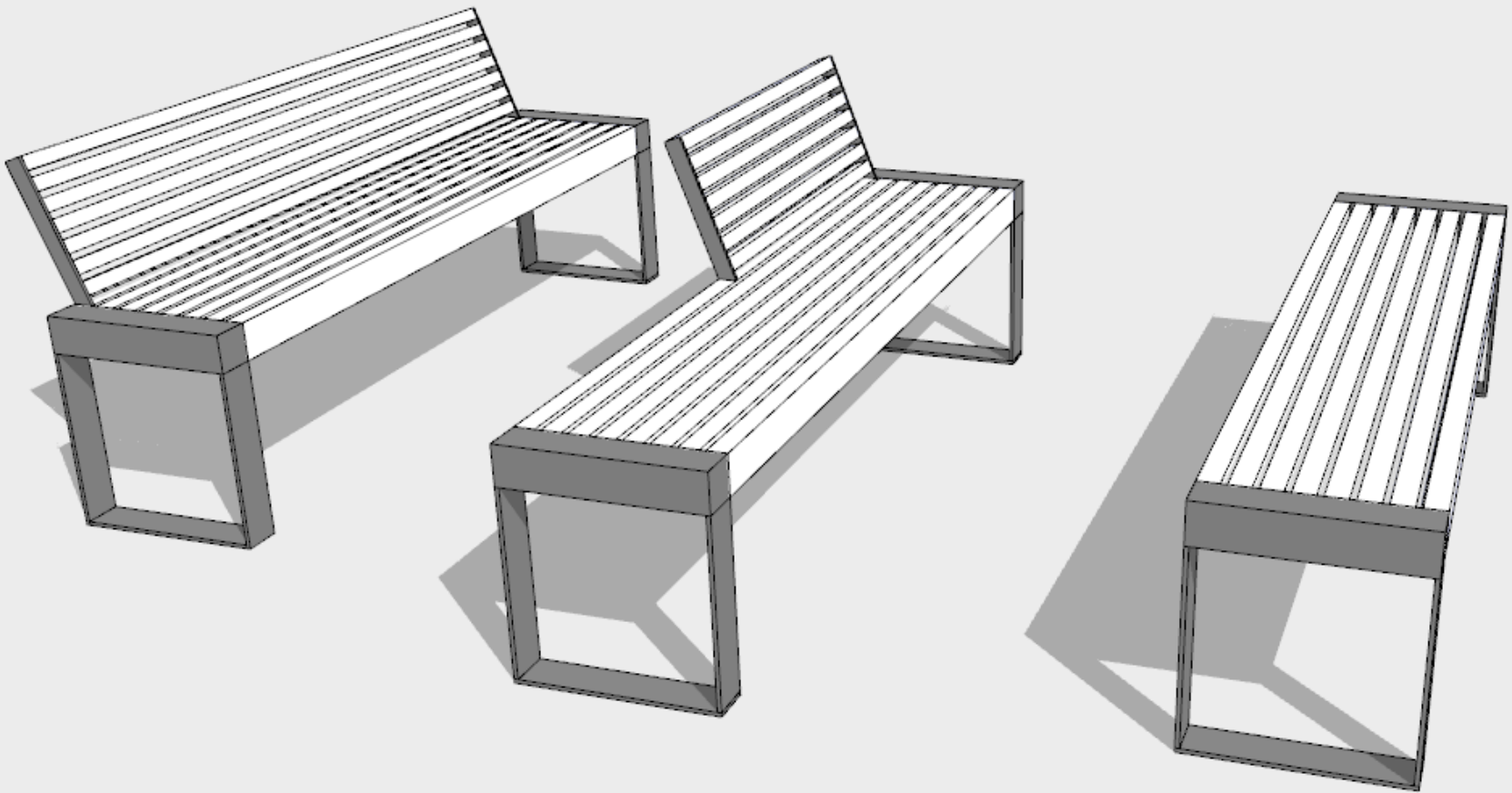



# SITZGELEGENHEITEN

„Erhöhte“ Sitzbank

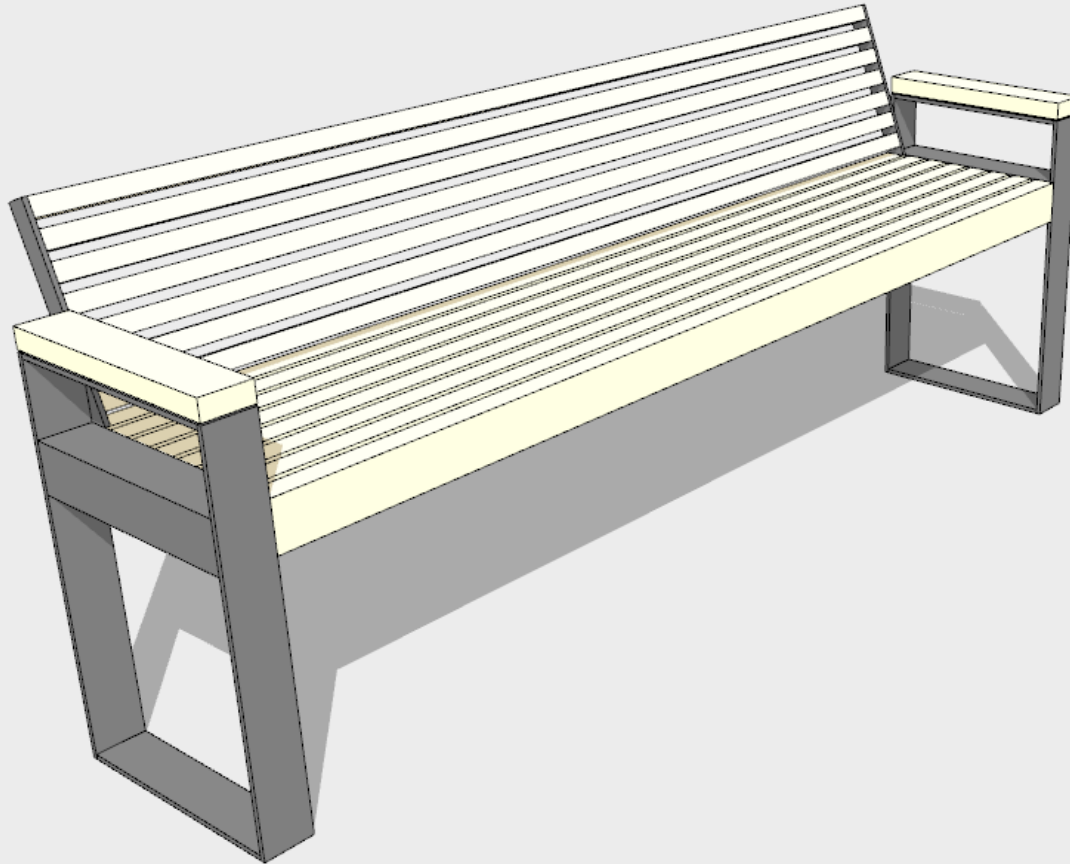



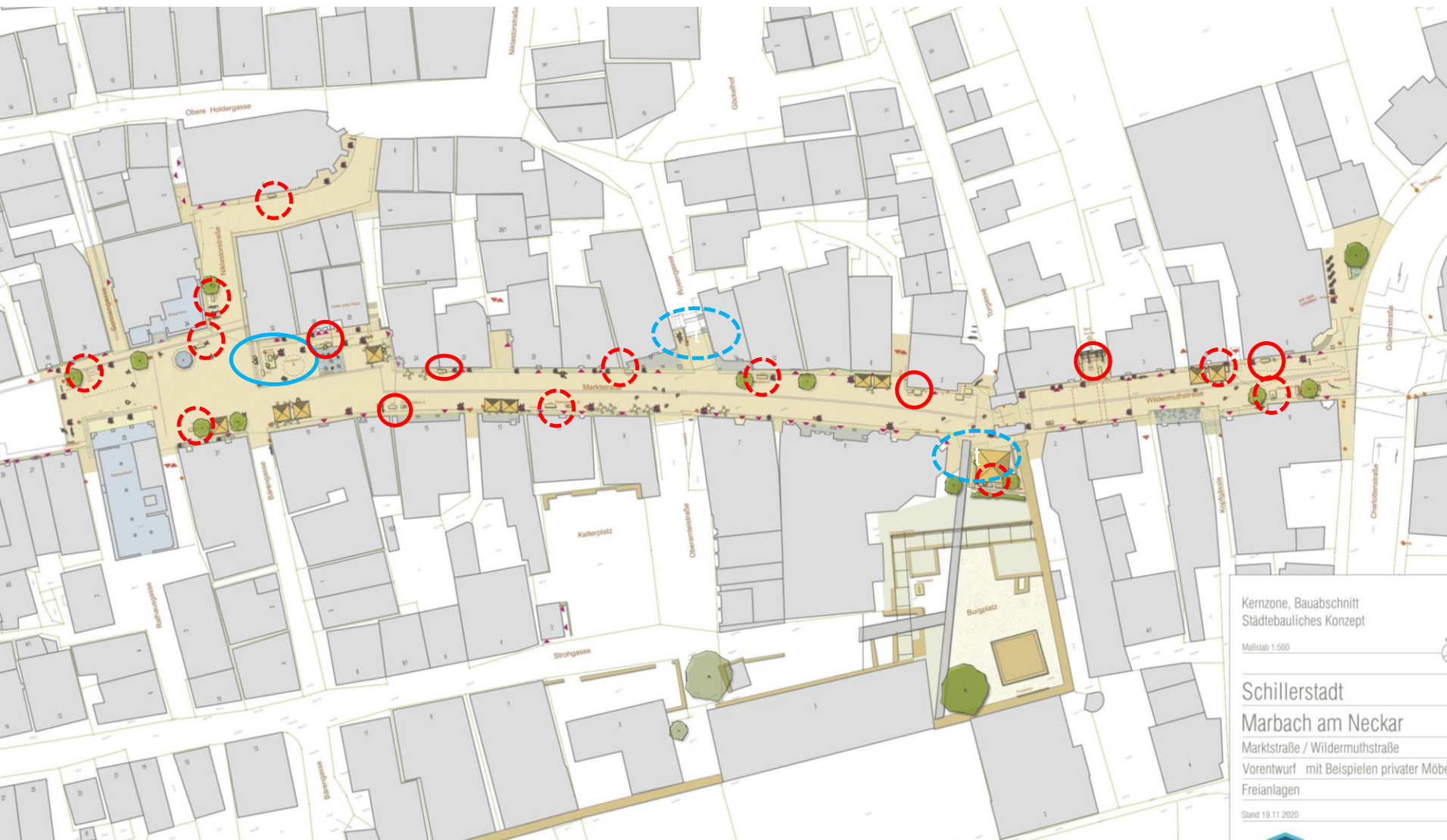

Kernzone, Bauabschnitt  
 Städtebauliches Konzept

Maßstab 1:500

---

Schillerstadt  
 Marbach am Neckar  
 Marktstraße / Widermuthstraße  
 Vorentwurf mit Beispielen privater Möbe  
 Freianlagen

Stand 19.11.2020

# Radbügel

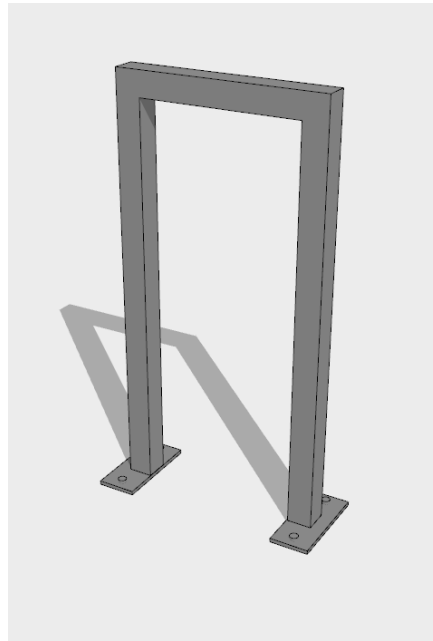

Gezogenes Quadratrohr / Rundrohr

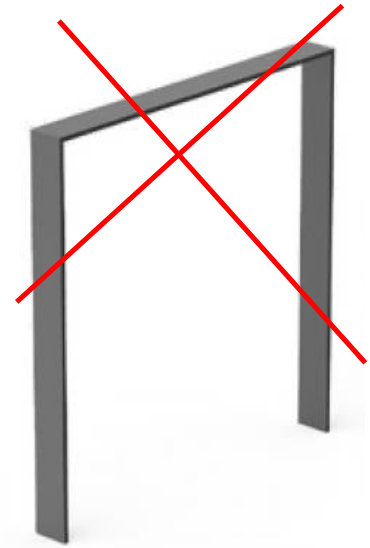





Kernzone, Bauabschnitt  
Städtebauliches Konzept

Mallstab 1:500

Schillerstadt  
Marbach am Neckar  
Marktstraße / Widernuthstraße  
Vorentwurf mit Beispielen privater Möbe  
Freianlagen

Stand 19.11.2020

# MÜLLBEHÄLTER

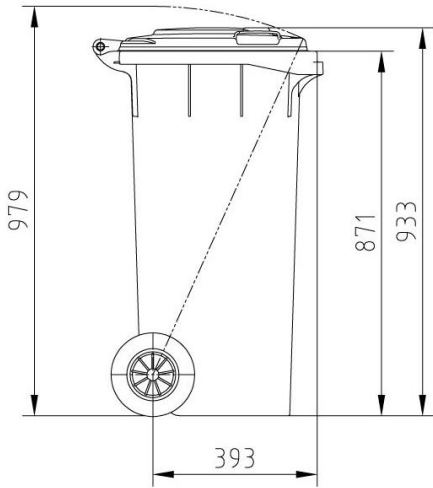
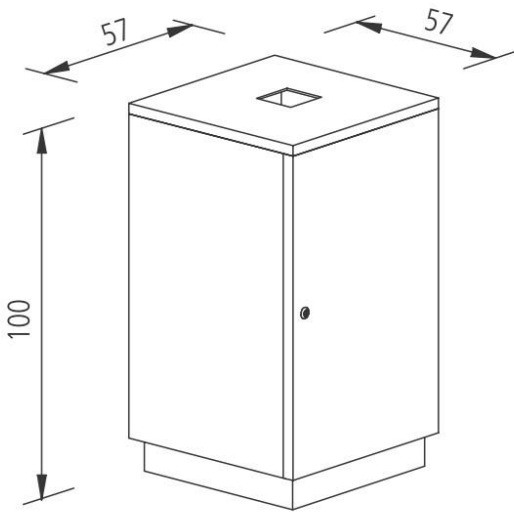



# Individuelle Gestaltung im Detail



# VITRINE KAPELLE

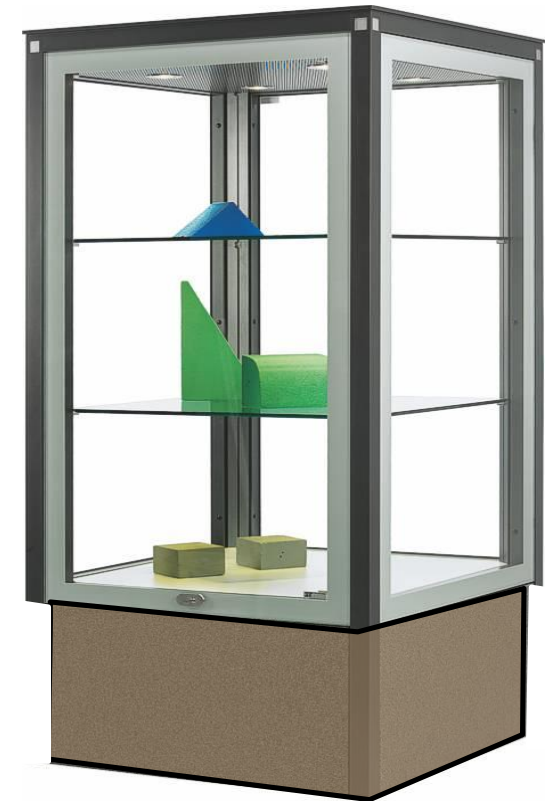



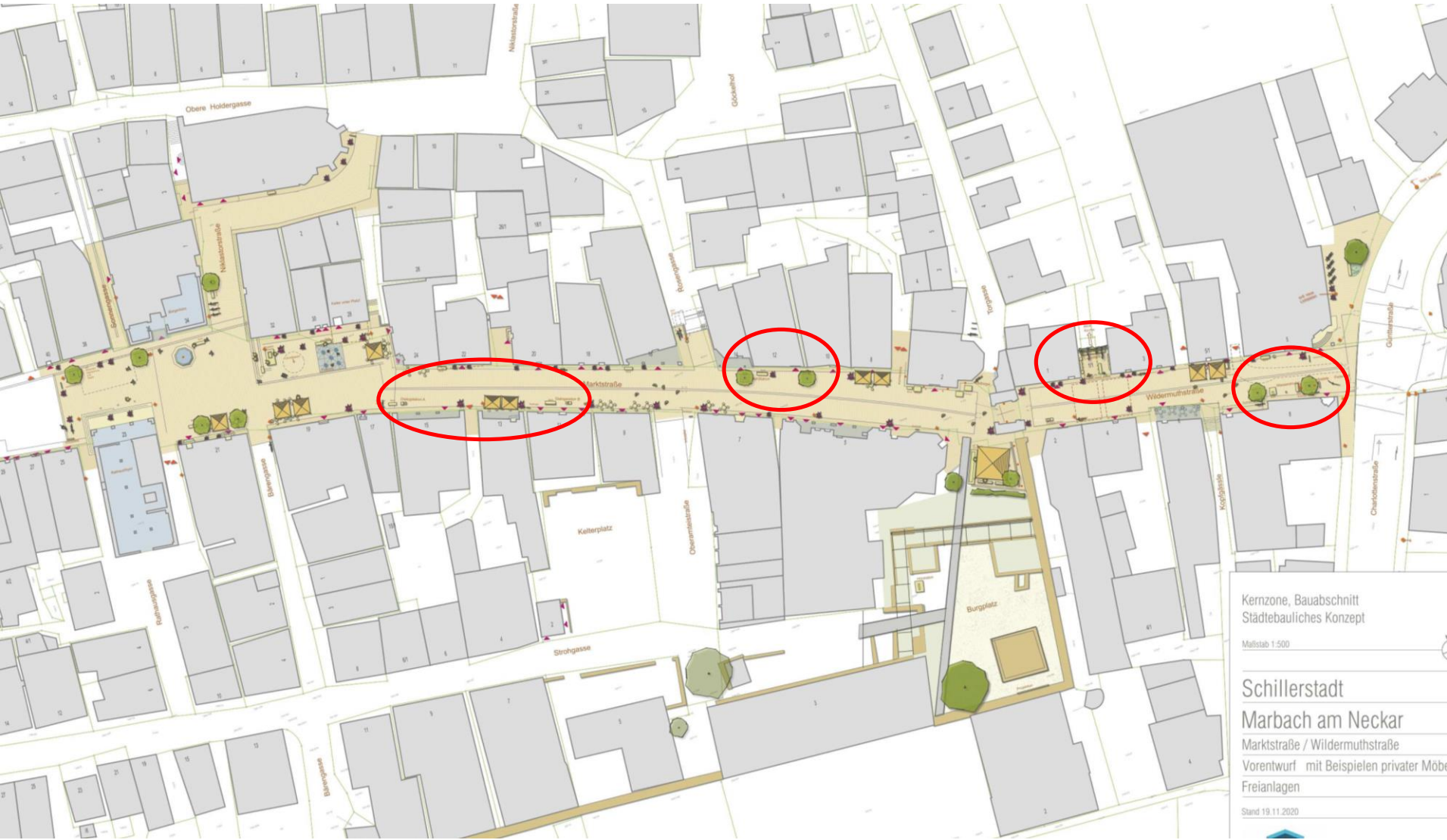

Kernzone, Bauabschnitt  
 Städtebauliches Konzept  
 Maßstab 1:500

---

Schillerstadt  
 Marbach am Neckar  
 Marktstraße / Widermuthstraße  
 Vorentwurf mit Beispielen privater Möbe  
 Freianlagen  
 Stand 19.11.2020

# Anziehungspunkte: STATIONEN - LESESTATION Lugplätzle







Weinlaube (Berankung), Bücherbox, u.a. Schillerliteratur, Sitzbänke, Vitrinen mit gleicher Farbe, ggf. Digitalmonitor, ggf. Interaktiv, Möbel z.T. demontabel

# STATIONEN - Weinleselaube Lugplätze



Weinlaube (Berankung), Bücherbox, u.a. Schillerliteratur, Sitzbänke, Vitrinen mit gleicher Farbe, ggf. Digitalmonitor, ggf. Interaktiv, Möbel z.T. demontabel



# Anziehungspunkte: DIALOGSTATION - Kommunikation über Distanzen

Z.B. Schillerdialoge miteinander sprechen, Liedtexte Rio Reiser, etc.....

Denkbar in Kombination mit einem QR-Code für Texte, die das Tourismusbüro anbietet.

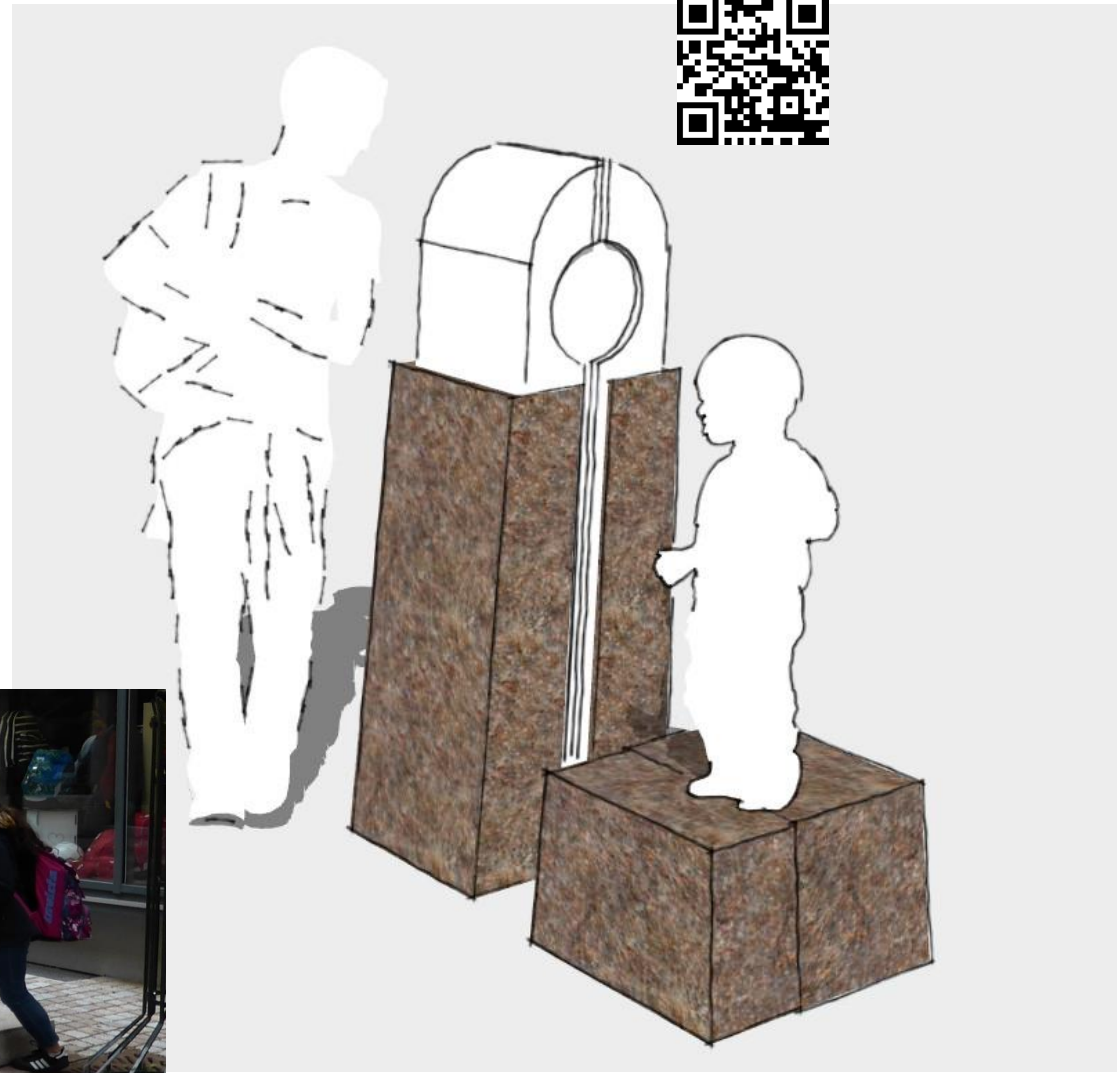
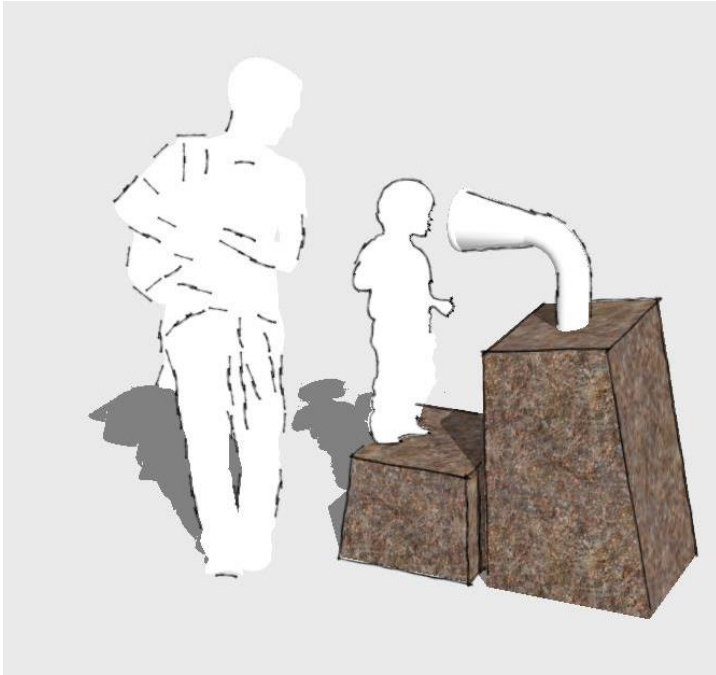

# STATIONEN - SEHSTATION – Kaleidoskop oder Fernrohr

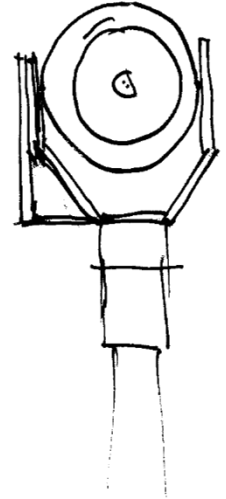
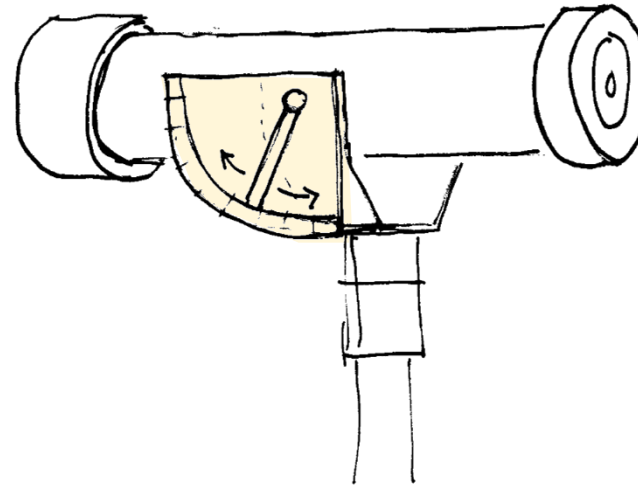

Fernrohr mit Winkelskala und Fixpunkten an Gebäuden für eine Berechnung der Höhe–

Mit Tafel oder Verknüpfung mit Internet (Tourismusbüro, TM-Museum)



# Anziehungspunkte: STATIONEN - Wasserstrudel -

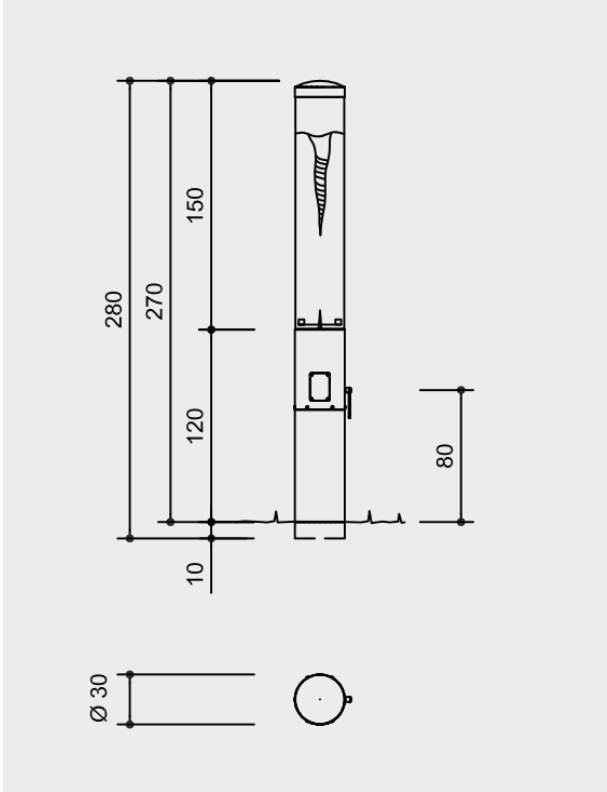











# BELEUCHTUNG - Varianten

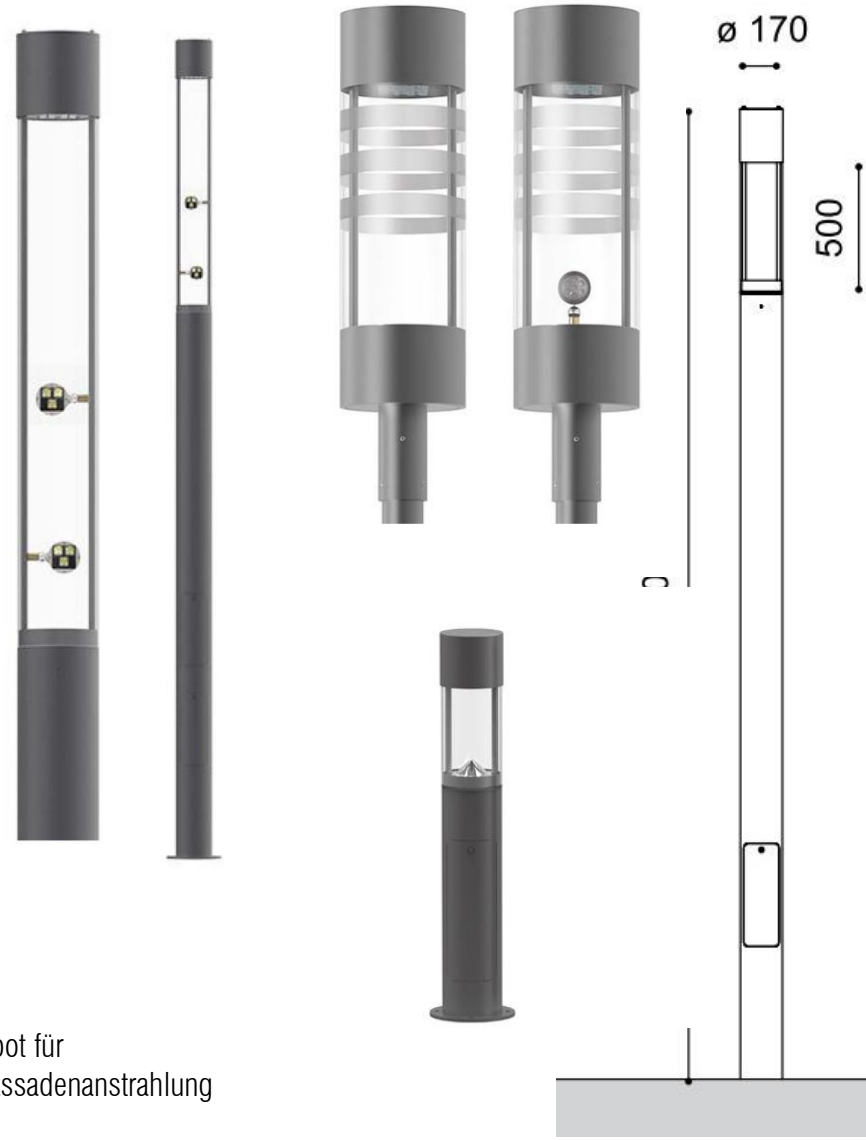

Spot für Fassadenanstrahlung

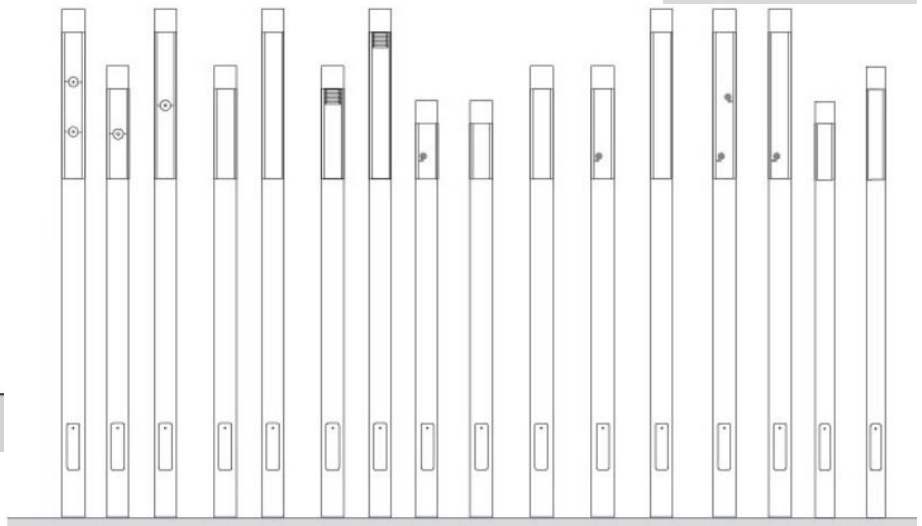
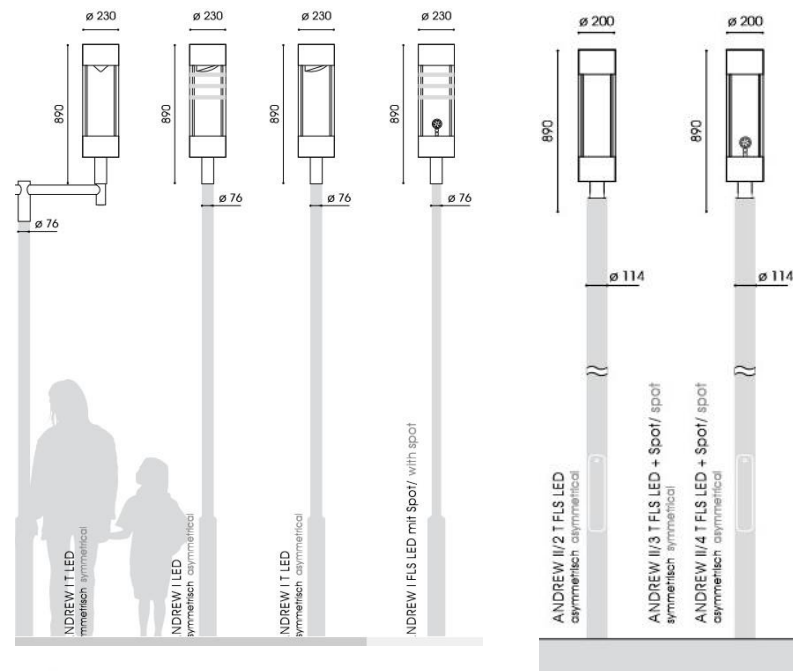

# Vorentwurf

# Wasser

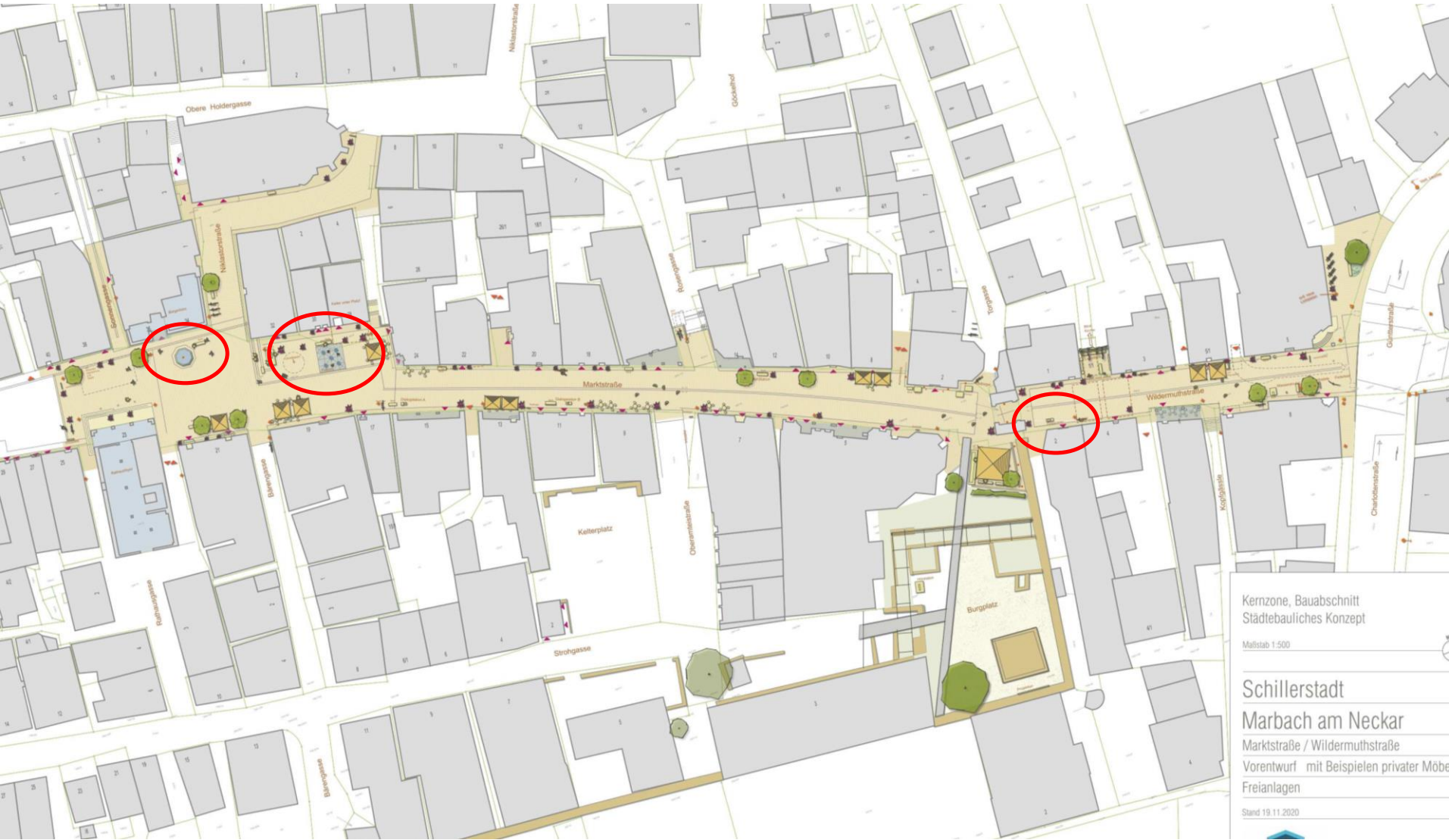

Kernzone, Bauabschnitt  
Städtebauliches Konzept

Mallstab 1:500

Schillerstadt

Marbach am Neckar

Marktstraße / Widernuthstraße

Vorentwurf mit Beispielen privater Möbe  
Freianlagen

Stand 19.11.2020





# TRINKBRUNNEN

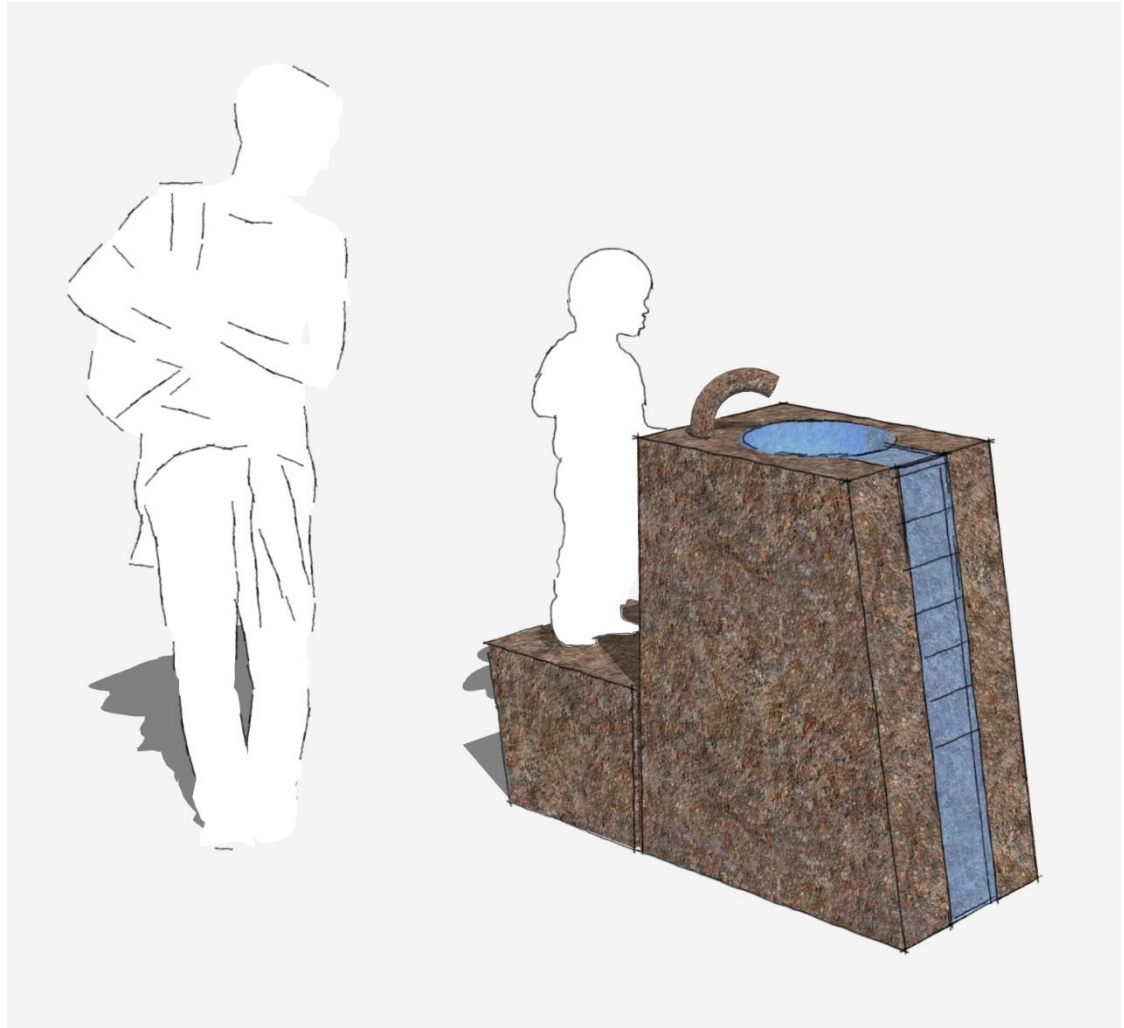
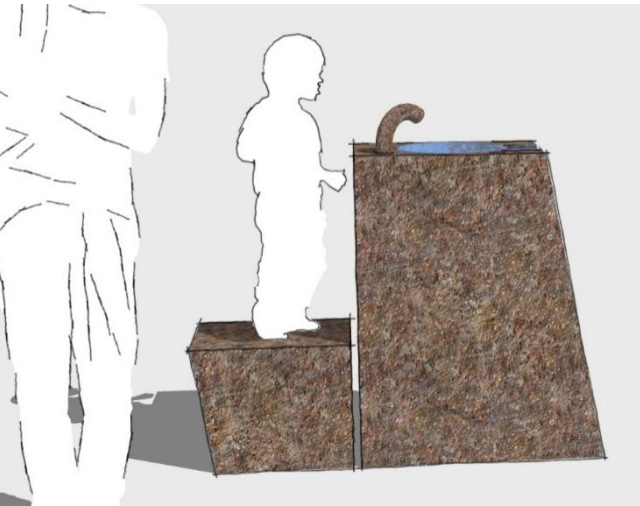

Natursteinquader (wie Belag) mit Bankauflagen





# WASSER



# WASSER





# Fontänenfeld





# Garagenausfahrt





# Garagenausfahrt





# Garagenausfahrt

















### Orientierung und Information

Stelen  
Stele  
vermaßt  
in mm  
M1:10

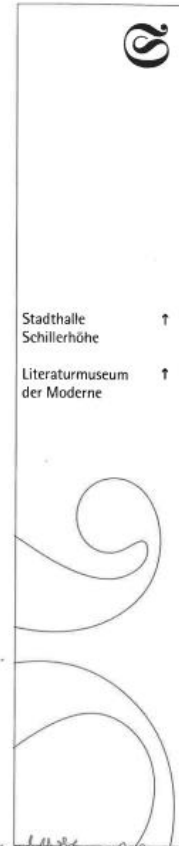

Stele  
Frontalansicht

Logo  
Material  
erhaben  
6 mm

Stele  
420 / 2100 mm  
Cortenstahl  
Material  
2 x 12 mm

Typografie  
erhaben  
6 mm

Logoausschnitt  
erhaben  
4 mm



### Stadthalle Schillerhöhe Marbach am Neckar

Corporate Identity  
Corporate Design

Orientierungs- und  
Informationssystem

Baumann & Baumann  
13.10.2008

B&B





## Gesamtkonzept - handwerkliche Konstruktionen

## Beispiel Calw

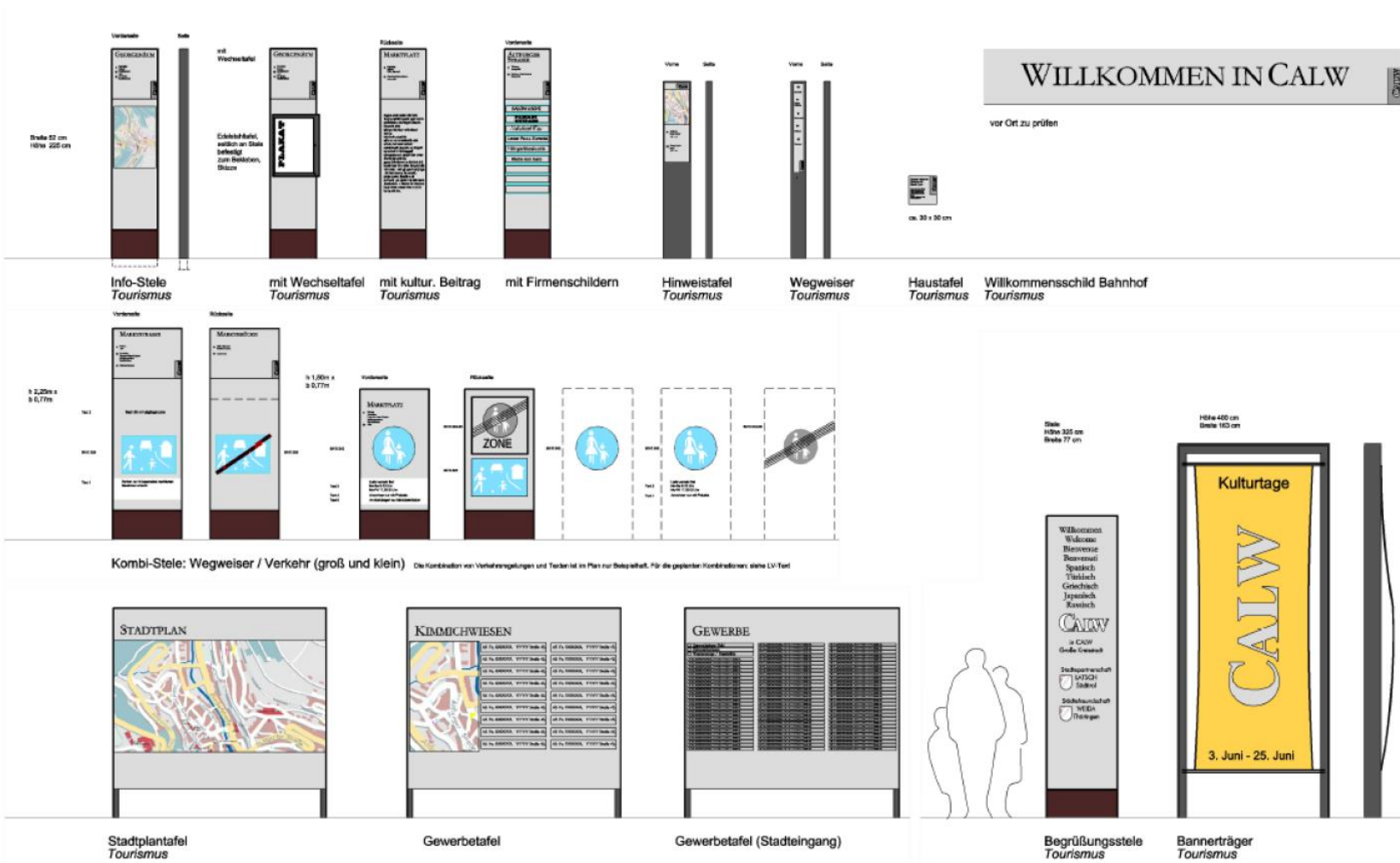



## Grundelement in Stelenform

- Für Stadtplan, Wegeföhrung und Verkehrsregelungen
- In Material und Konstruktion regional => Stadtmarke





Einfache Konstruktion mit gängigen Profilen =>

- für jede Aufgabe eine passende Lösung,
- nach Jahren nachrüstbar, an neue Drucktechnik anpassbar
- In Material, Form, Farben und Design durchgängig
- wiedererkennbar





In Material, Konstruktion, Farbe und Druckdesign durchgängig und wiedererkennbar.  
Abgewandelt für den jeweiligen Einsatz



Friedhofstafel



Wegweiser und Fahrplanvitrine am ZOB

Rathausvitrine und -briefkasten

Informationsvitrine Wohnwagenplatz mit Broschürenfach



# Vorentwurf





# Vorentwurf





# TEMPORÄRE ÜBERDACHUNG



# TEMPORÄRE ÜBERDACHUNG



Beispiel Fa. Solona





# SONNENGASSE NIKLASTORSTRASSE





# SONNENGASSE NIKLASTORSTRASSE





# ROSENGASSE





# ROSENGASSE





# PLATZ AM TORTURM



# PLATZ AM TORTURM





# PLATZ AM TORTURM





# PLATZ AM TORTURM





# PLATZ AM TORTURM





# Bereich Rathaus













# Vorentwurf



Kernzone, Bauabschnitt  
 Städtebauliches Konzept

Maßstab 1:500

Schillerstadt  
 Marbach am Neckar  
 Marktstraße / Wildermuthstraße  
 Vorentwurf mit Beispielen privater Möbe  
 Freianlagen

Stand 19.11.2020

# Vorentwurf

Mit Möblierung der Anlieger







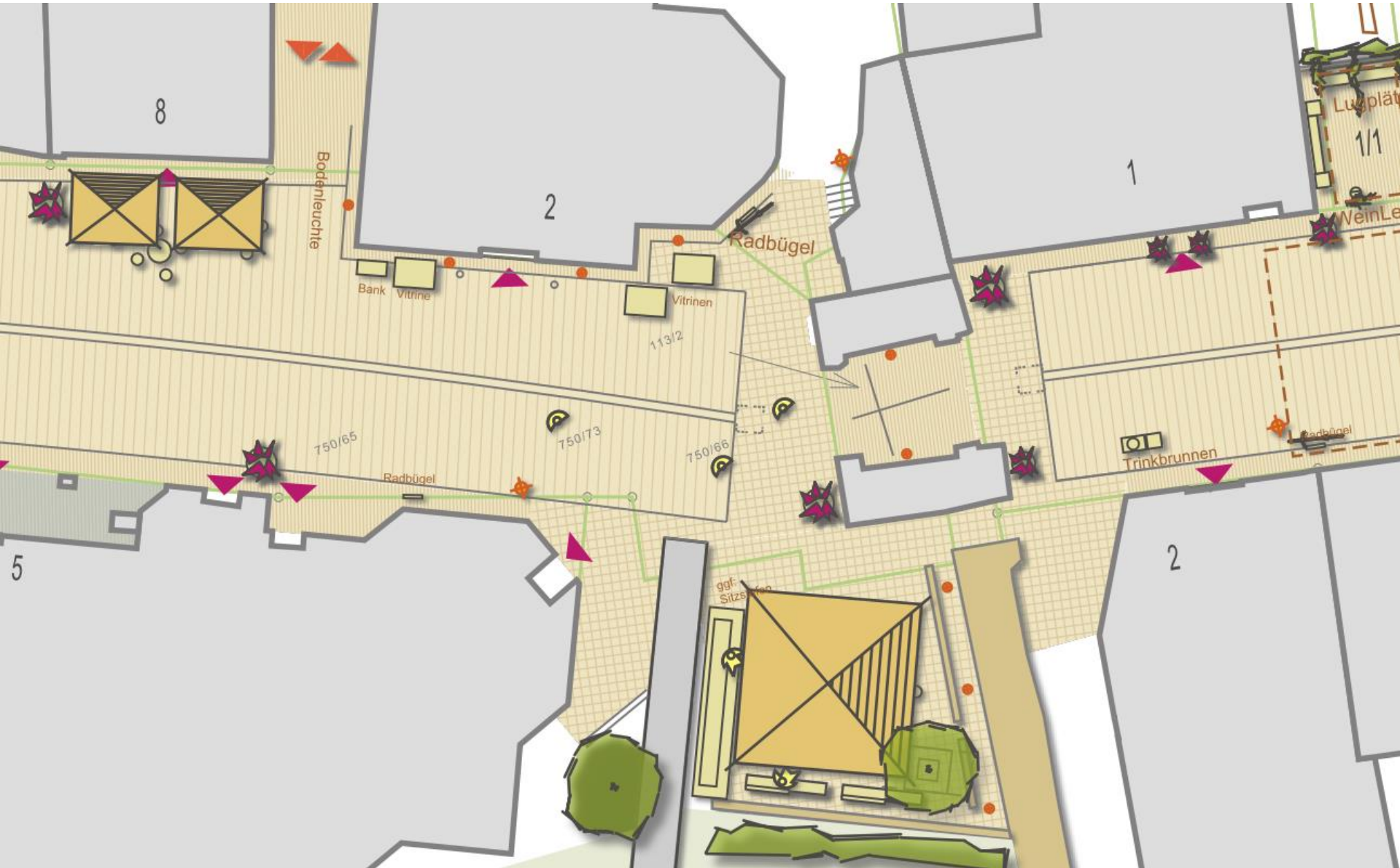



# Vorentwurf

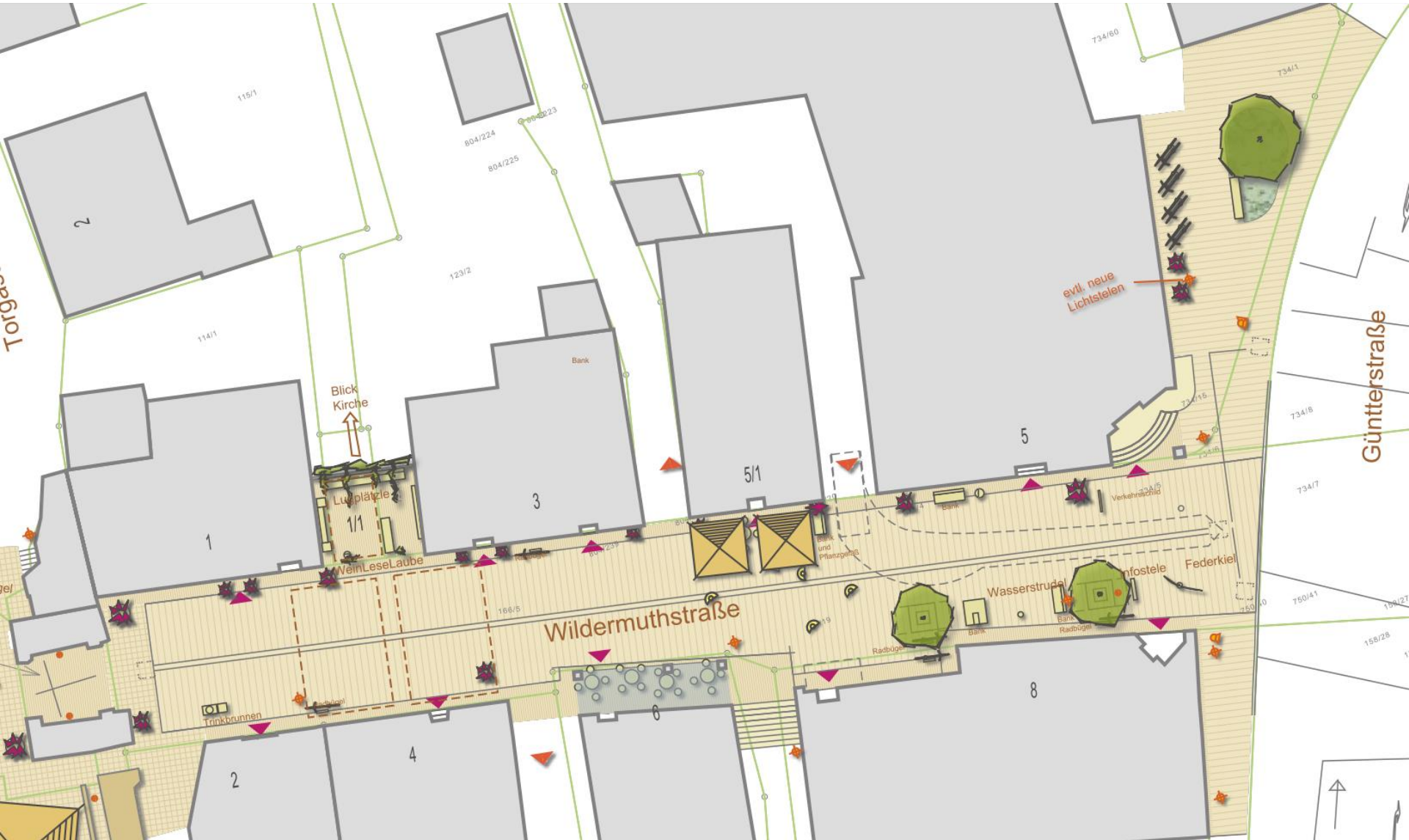

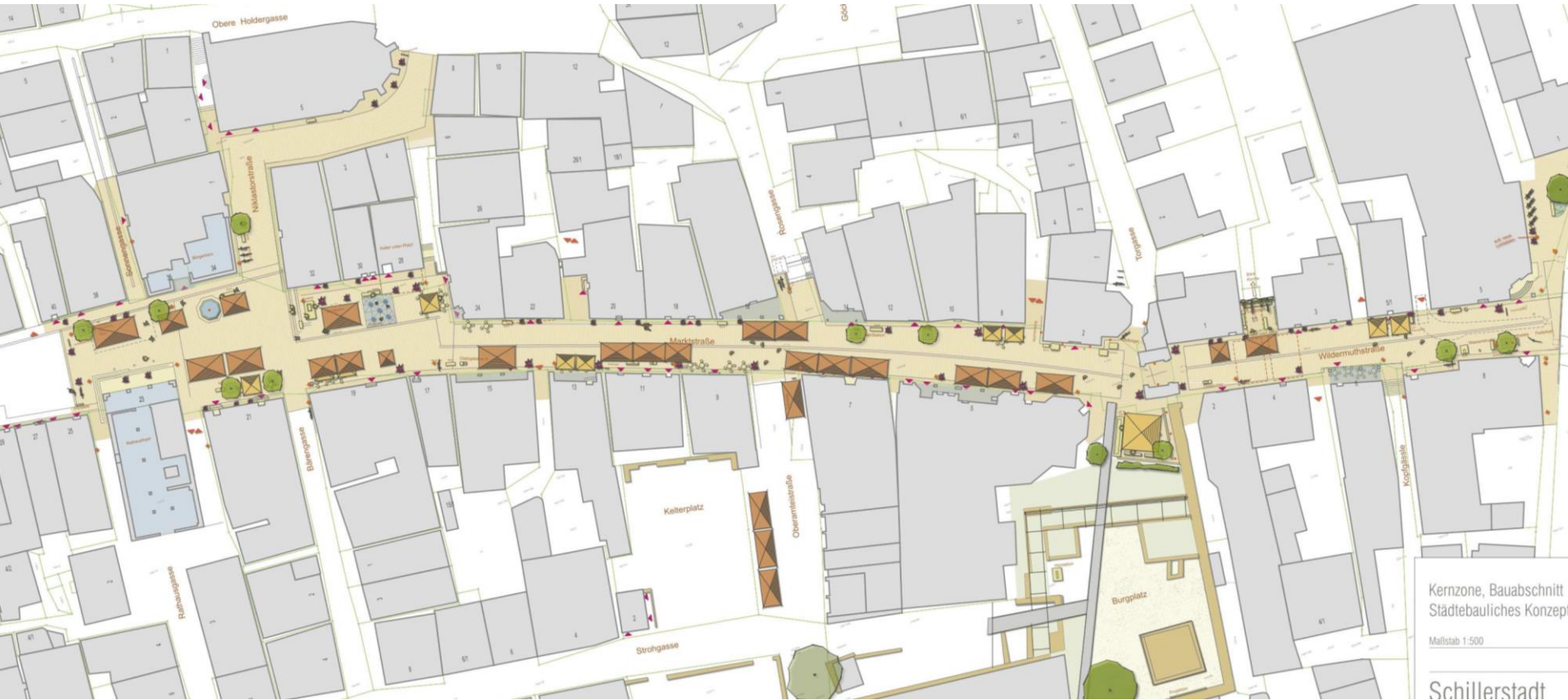

Kernzone, Bauabschnitt  
Städtebauliches Konzept

Maßstab 1:500

Schillerstadt



**baldauf**  
ARCHITEKTEN  
STADTPLANER



**Baldauf Architekten und Stadtplaner GmbH**

Geschäftsführer: Prof. Dr. Ing. Gerd Baldauf

Freier Architekt BDA und Stadtplaner

Schreiberstraße 27 · 70199 Stuttgart

Tel. 0711 967 87-0 · Fax 0711 967 87-22

info@baldaufarchitekten.de · www.baldaufarchitekten.de